



DRYER AMP SENSOR FAN CONTROL WITH SURGE PROTECTION

This controller senses when a clothes dryer is drawing 1.2 AMP of current. When this occurs a relay contact closes turning the dryer vent booster fan "ON". When current drops below the 2 AMP threshold the relay contacts open turning the booster fan "OFF".

The sensor is designed to mount in a standard electrical box. The AMP Sensor may be placed in an electrical box adjacent to the junction box in which the wires supplying power to the dryer are located (see back of this page). The dryer supply neutral (white) wire passes through the center of the AMP Sensor donut. No physical connection is made.

NOTE:

Installation by a licensed electrician is recommended. Installation and use of this equipment should be in accordance with provisions of the national electrical code. Applicable local codes and pertinent industry standards should be verified before installation.

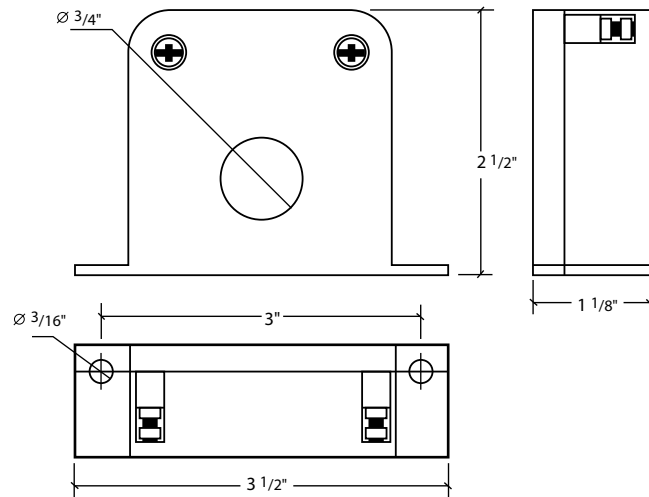

SPECIFICATIONS

Action Current Range:	1.20-60 AMP-turns
AC Conductor Hole:	19 mm (0.75") diameter
Trip Set-Point:	Pre-set at approximately 1.2A
Switch Rating:	120 VAC 3.5A max.
Output Type:	Triac with volts surge protected design
Operating Temperature:	-5 ~ +40° C (23 ~ 104° F)
Operating Humidity:	0 ~ 99%
Dimensions:	H63 x W89 x D28 mm (2.5" x 3.5" x 1.1")
Mounting Holes:	2 x 5 mm (2 x 0.19") holes spaced 76 mm (3") on base
Leakage Current:	< 1 mA
Manufacturing Process:	ISO 9001 Certified
Standards Met:	CSA No.14-2005 edition, UL 508, FCC, IEEE 62.41-1991

TURN POWER OFF AT CIRCUIT BREAKER OR FUSE PANEL BEFORE INSTALLATION

INSTALLATION INSTRUCTIONS

INSTALLATION TYPE 1

(at dryer junction box)

1. Attach electrical junction box to the dryer junction box.
2. Disconnect and loop neutral (white) dryer power supply wire through center of sensor as shown then back to the dryer junction box and re-connect.
3. Mount sensor in the electrical box (two holes may have to be drilled for mounting).
4. Connect fan 120 VAC power supply to the top (relay) terminals of the sensor.

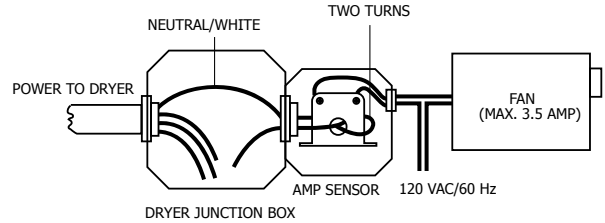

NOTE:

If the dryer cooling motor is less than 0.6 AMP, you may have to increase numbers of turns to operate AMP Sensor switch. But make sure numbers of turns multiply by dryer max. input current (AMP) must be less than 60 AMP (see action current range on page 1)

INSTALLATION TYPE 2

(at fuse/breaker panel)

1. Mount sensor at a convenient location on the fuse/breaker panel.
2. Disconnect and loop neutral (white) dryer power supply wire through center of sensor then re-connect.
3. Connect fan 120 VAC power supply to the top (relay) terminals of the sensor.

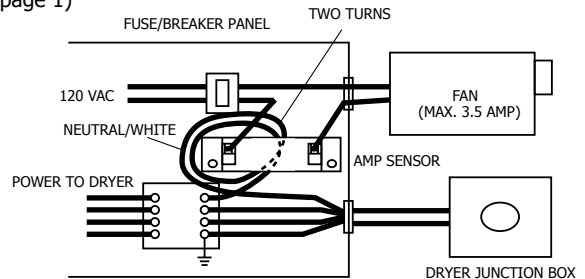

INSTALLATION TYPE 3

(inside dryer compartment)

1. Mount sensor in a convenient location inside the dryer connection compartment.
2. Disconnect and loop neutral (white) dryer power supply wire through center then re-connect.
3. Connect fan 120 VAC power supply to the top (relay) terminals of the sensor.

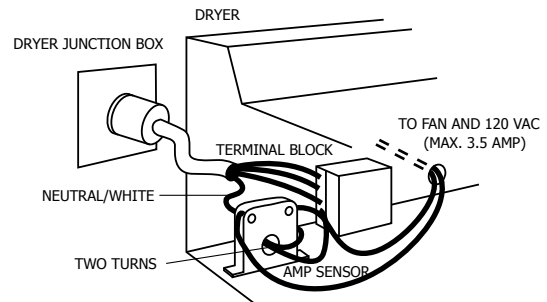

INSTALLATION TYPE 4

(for stacker dryer C/W common power supply - US only)

Stacker Dryer that has separate power supply for dryer and washer, use instruction 1, 2 or 3.

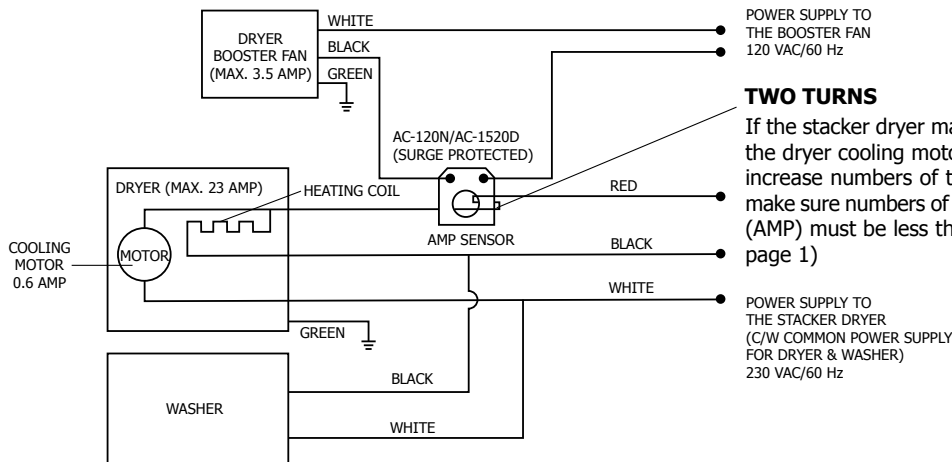

TWO TURNS

If the stacker dryer max. input current is less than 20 AMP and the dryer cooling motor is less than 0.6 AMP, you may have to increase numbers of turns to operate AMP Sensor switch. But make sure numbers of turns multiply by dryer max. input current (AMP) must be less than 60 AMP (see action current range on page 1)

Reversomatic Manufacturing Ltd.

790 Rowntree Dairy Road, Woodbridge, ON Canada L4L 5V3 • Tel: 905-851-6701 • Fax: 905-851-8376
www.reversomatic.com • info@reversomatic.com