



BATHROOM EXHAUST FANS

Models: QCF-80ES/(S), QCF-95, QK-180 ES, RCF 100-3
QK-130 ES/BC, QK-150 ES, QK-160 ES,

INSTALLATION AND OPERATING INSTRUCTIONS

IMPORTANT SAFETY INSTRUCTIONS READ AND SAVE THESE INSTRUCTIONS

WARNING

TO REDUCE THE RISK OF FIRE, ELECTRIC SHOCK OR INJURY, OBSERVE THE FOLLOWING:-

1. Read all the instructions carefully before installation, operation or maintenance of the fan. Failure to comply with instructions could result in personal injury and/or property damage.
2. Installation of the fan and the corresponding electrical wiring must be done by a qualified person and be in accordance with all municipal and national electrical Codes and pertinent industry standards should be verified before installation.
3. Use the unit only for the intended applications and in the manner indicated by the manufacturer. If you have any questions please contact the manufacturer at the address or telephone number listed in the warranty.
4. Moving Parts, Disconnect Power supply before opening. Ensure that all the nuts and screws are securely fastened before restarting the unit.
5. Before wiring, servicing or cleaning the unit, switch power off at the service panel and lock it. If service panel is unlocked others could turn the power on unexpectedly and cause fatal electric shock to the installer.
6. When cutting or drilling into wall or ceiling, make sure that you do not damage electrical wiring and other hidden utilities.
7. Always vent the unit to the outdoors, NOT into unventilated spaces such as garages, attics, crawl spaces, etc.
8. The unit must be grounded.
9. Do not use any accessories not recommended by the manufacturer.
10. Do not use to exhaust hazardous or explosive materials and vapors.
11. Do not use this fan with any solid-state speed control device such as dimmer.
12. Never place a switch where it can be reached from a bathtub or shower.
13. Always use metal duct work to reduce the risk of fire.

To ensure the best air and sound performance make sure the duct work size is a minimum of the discharge. Do not reduce. Reducing the duct size can increase fan noise. It is recommended that the largest diameter ducting is used (5" or 6"). The length of ducting and the number of elbows should be kept to a minimum. As well to protect against condensation problems use insulated ducting. Hard ducting will provide maximum air delivery - if using flexible ducting always ensure it is pulled as tight as possible. Using a short section of flexible ducting in combination with hard ducting will reduce noise transmission.

Note: The ducting from this fan to the outside of the building has a strong effect on the air flow, noise and energy use of the fan. Use the shortest, straightest duct routing possible for best performance, and avoid installing the fan with smaller ducts than recommended. Insulation around the ducts can reduce energy loss and inhibit mold growth. Fans installed with existing ducts may not achieve their rated air flow.



REVERSOMATIC
MANUFACTURING LIMITED

790 Rowntree Dairy Road, Woodbridge ON, Canada L4L 5V3
Tel: 905-851-6701 • Fax: 905-851-8376 • info@reversomatic.com

www.reversomatic.com

TYPICAL INSTALATION

QCF-80ES
 QCF-80ES (S)
 QK-130BC
 QK-130ES
 QK-150ES
 QK-160ES
 QK-180ES
 RCF100-3
 QCF-95

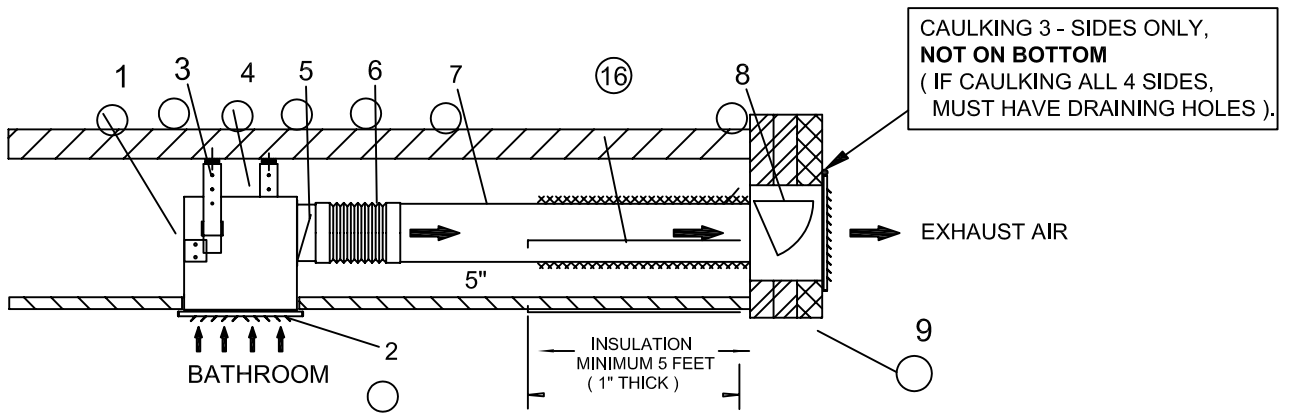

IN LINE INSTALATION

QCF-80ES
 QCF-80ES (S)
 QK-130ES/BC
 QK-150ES

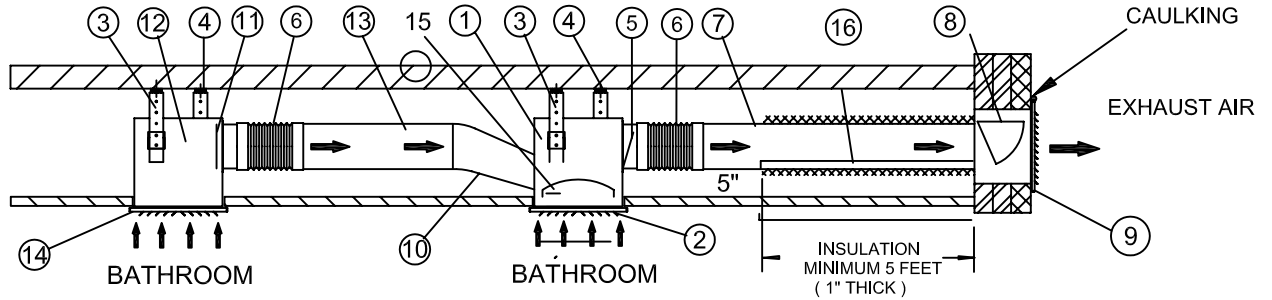

- | | |
|---|---|
| <ol style="list-style-type: none"> 1. FAN 2. FAN INLET GRILLE 3. MOUNTING BRACKET 4. RUBBER MOUNT * 5. NEOPRENE BACK DRAFT DAMPER 6. FLEXIBLE CANVAS DUCT CONNECTOR 7. DISCHARGE PIPE 8. LEAKPROOF WALL BOX 9. LEAKPROOF GRILLE (FOR WALL BOX) | <ol style="list-style-type: none"> 10. TRANSITION (FOR INLINE INSTALLATION) 11. HAND ADJUSTABLE BALANCE DAMPER
C/W NEOPRENE BACKDRAFT DAMPER 12. BALANCE BOX 13. INTAKE PIPE 14. GRILLE (FOR BALANCE BOX) 15. BAFFLE 16. DUCT INSULATION |
|---|---|

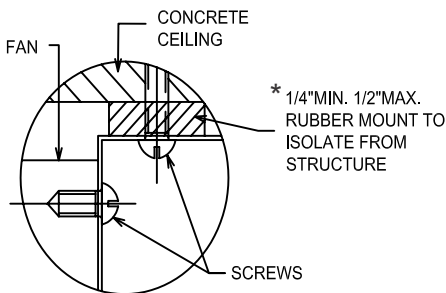

* Not Supplied

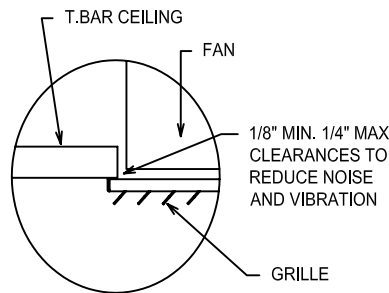

TYPICAL WIRING DIAGRAM (For RCF100-3 only)

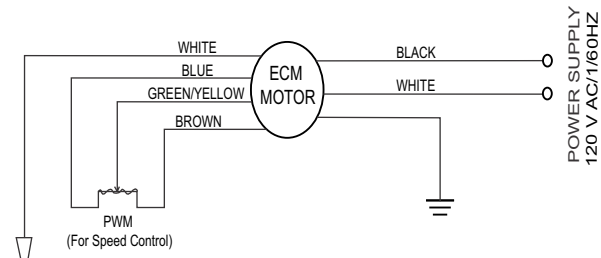

WIRING DIAGRAM

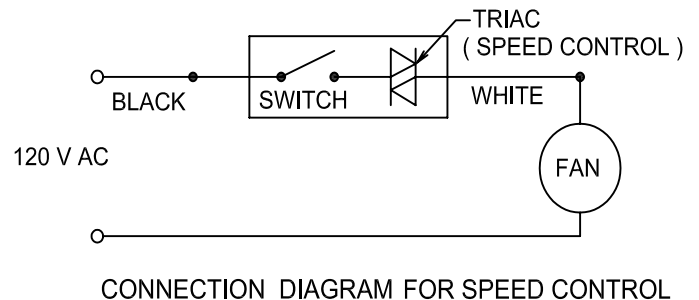
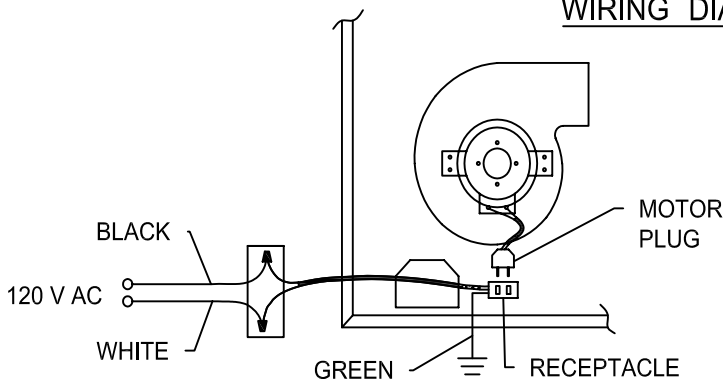

REVERSOMATIC
 MANUFACTURING LIMITED

790 Rowntree Dairy Road, Woodbridge ON, Canada L4L 5V3
 Tel: 905-851-6701 • Fax: 905-851-8376 • info@reversomatic.com

www.reversomatic.com