



HEPA Air Cleaner

RAC-200/400

**DUCT MOUNTED HEPA FILTRATION SYSTEM TO KEEP YOUR FAMILY HEALTHY
DO NOT LET INDOOR AIR POLLUTANTS AFFECT YOUR HOME**

Features:

- Power Ratings: 115VAC/1/60Hz, 1.30 Amp., (RAC-200), 2.75 Amp. (RAC-400).
- The air cleaner is powered by a high-performance and backward inclined PSC motor to ensure a consistent and maintenance free life cycle.
- The positioning of the motor between the pre-filter and the HEPA filter creates a **dual-barrier system**, ensuring that the air cleaner will perform consistently at a comfortable level.
- The air cleaner is also lined with insulation that further contributes to the low sound level of the unit.
- The **modular** design makes removing the filters easy and hassle-free with an accessible front door and sliding panels.
- A two filter system captures and removes the pollutants and allergens from your home. The **pre-filter** collects the largest particles while the **carbon filter** absorbs odors and gases. The **HEPA filter** captures the tiniest particles.
- HEPA filter media - 99.97% effective down to 0.3µ.
The filter will capture up to 99.97% of particles larger than 0.3µ - a human hair is 100µ.
- On average, the pre-filter and carbon filter should be replaced every 3 to 6 months whereas the HEPA filter should be replaced every 2 to 5 years.



Accessories (Optional):

- Replacement Filter Kit
- UV Light
- Polypropylene caster wheels (for stand alone unit)

Performance Features:

Dimension	Air Cleaner - Height: 24" Width: 12.75" Length: 17" Pre-filter - Height: 2" Width: 11.5" Length: 15.75" HEPA filter - Height: 2.5" Width: 11.5" Length: 15.75"
Motor	Powerful PSC motor with external motorized impeller with permanently lubricated ball bearings for long life and vibration-free operation
Electrical	Pre-wired 3-feet long cord c/w three prong plug. Voltage: 115V/ 1 /60Hz Power Consumption: 120 Watts (RAC-200), 300 Watts (RAC-400)
Installation	Easy to install on existing duct work of forced air furnace or air handler. Mounts in any position. Can also be used as an independent system (stand alone)
Air flow	RAC-200: 200 CFM RAC-400: 400 CFM
Weight	App. 30.5 lbs (RAC-200) App. 35 lbs (RAC-400)



HEPA Air Cleaner

RAC-200/400

Performance Data

External Static Pressure		Net Supply Air Flow (CFM)	
Pa	in. W.C.	RAC 200	RAC 400
25	0.1	197	376
50	0.2	178	368
75	0.3	164	353
100	0.4	157	345
125	0.5	138	337
150	0.6	120	329
175	0.7	108	322
200	0.8	92	314
225	0.9	79	306
250	1.0	63	297

Installation Options:

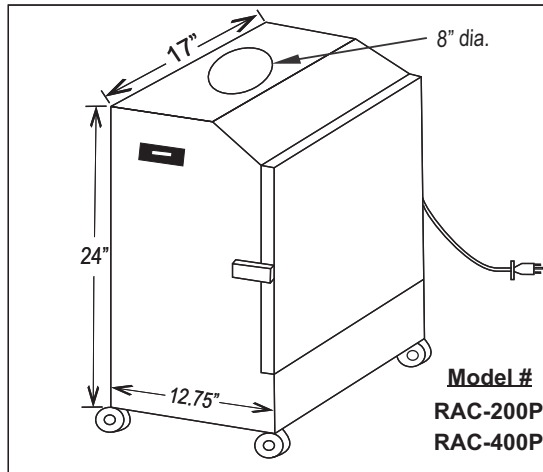

Sound Data:

RAC-200	RAC-400
2.0 Sones at Operating Speed	2.5 Sones at Operating Speed

* Tested at 5 ft. distance

#1 Free Standing (Stand alone)

Installation Type# A (Surface Mount)

Installation Type# B (Duct Mount)

Step#1
Install mounting angle as shown on return air duct for bottom support using # 8 x 1/2" screws

Step#2
Install Mounting angle on both sides of the unit by removing & remounting screws located on the unit

Step#3
Make knock out for intake & Exhaust on return air duct using template

Step#4
Mount unit to the return Air duct as shown using # 8 x 1/2" metal screws

Step#1
Install mounting angle as shown on return air duct for bottom support using # 8 x 1/2" screws

Step#2
Install Mounting angle on both sides of the unit by removing & remounting screws located on the unit

Step#3
Mount unit to the return Air duct as shown using # 8 x 1/2" metal screws

Step#4
Mount 8" dia. collar (optional) on intake (top) and exhaust (bottom) of the unit. Install metal duct work as shown

Note: Remove filter from plastic bags and reinstall in to the unit before running

Contractor:		RAC-200/400		
Architect:	Job:	Date	Superse.des	Drawing No.
Engineer:	Date Submitted:	07/20/18		

Reversomatic Manufacturing Ltd.

790 Rowntree Dairy Road, Woodbridge, ON Canada L4L 5V3 • Tel: 905-851-6701 • Fax: 905-851-8376
www.reversomatic.com • info@reversomatic.com